

Product Description

Product Description

The SGM-A series of dosing pumps offer the high performance with the capacity up to 1200L/H and with outstanding values for pressure applications up to 12 Bar. This series dosing pump is designed for durability and cost effectiveness, which is welcome to be used in lots of lines, such as the water treatment, chemical, power, food and beverage, paper, textile etc.

	l/h	(Mpa)		(mm)	(mm)	(KW)	(KG)
SGM-A 2.25/1.2	2.25	1.2	36	1.2	DN8	0.37KW	18
SGM-A 4.5/1.2	4.5						
SGM-A 9/1.2	9		144				
SGM-A 22/1.2	22		72	4			
SGM-A 44/1.2	44	144					
SGM-A 85/1.0	85	1	72	6	DN15		
SGM-A 120/0.7	120	0.7	72	8			
SGM-A 170/0.7	170		144	6			
SGM-A 240/0.7	240		144	8			
SGM -A 315/0.5	315	0.5	144	8	DN25		
SGM-A 400/0.5	400		144	10			
SGM-A 500/0.5	500		180				

Capacity (LPH)	PVC head		
	A/B	C	D
2.25~9	102	121	291
22~44	124	121	299
85~170	137	137	360
240~500	142	142	378

Capacity (LPH)	SS head		
	A/B	C	D
2.25~9	102	121	289
22~44	115	121	299
85~170	169	130	352
240~500	178	142	355

Capacity (LPH)	Connection	
	PVC head	SS head
2.25~9	DN8 PVC Connection	DN8 Thread
22--170	DN15 PVC Connection	DN15 Thread
240~500	DN15 PVC Connection	DN25 Thread

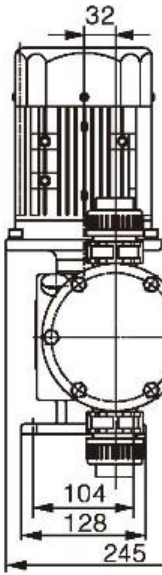
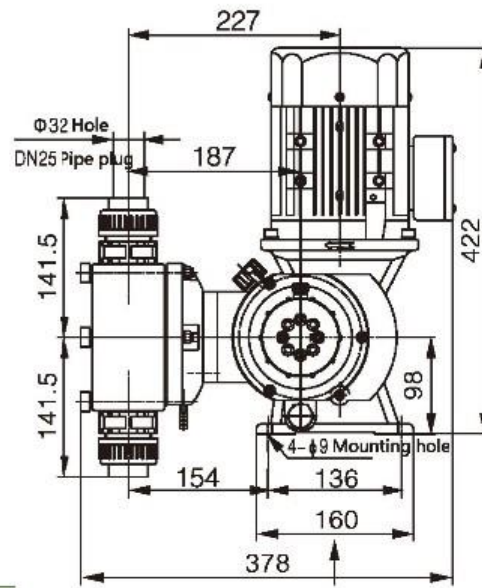

Products Show



Technical Specifications

- * Flow rates up to 500L/H, pressure up to 12Bar
- * Adjustment of flowrate from 0% - 100% while running or stopped
- * Accuracy +/- 2% of 100% rated flow
- * Mechanically actuated PTFE diaphragm

- * Maximum temperature of pumped fluid: +10°C - 40°C

- * Maximum suction up to 2M

Features & Benefits

- * Mechanical actuated diaphragm design, easy operation and with the convenience maintenance

- * Changeable eccentric drive, no leakage with security delivery

- * Rugged construction designed to withstand tough environments

- * Oil bath lubrication for all of drive components

- * Various pump head material (PVC, PVDF, SS304, SS316 etc.) to me